

REV	ZONE	DESCRIPTIONS	DRWN	APPVD

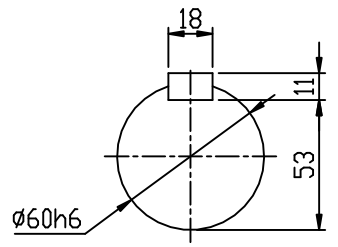

OUTPUT SHAFT

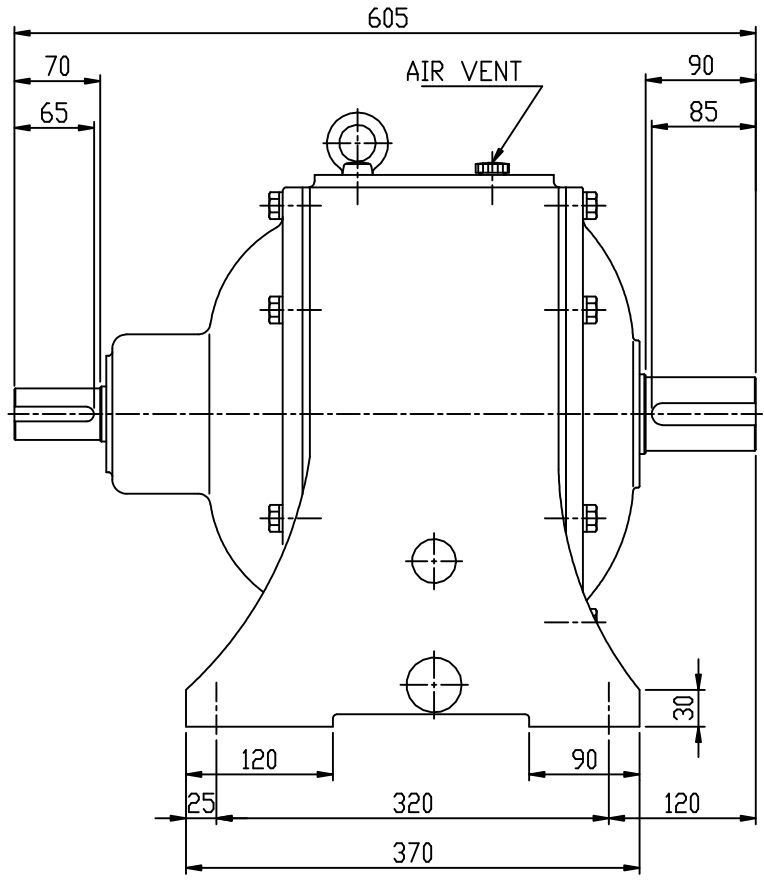
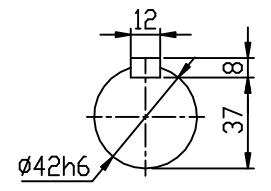

INPUT SHAFT

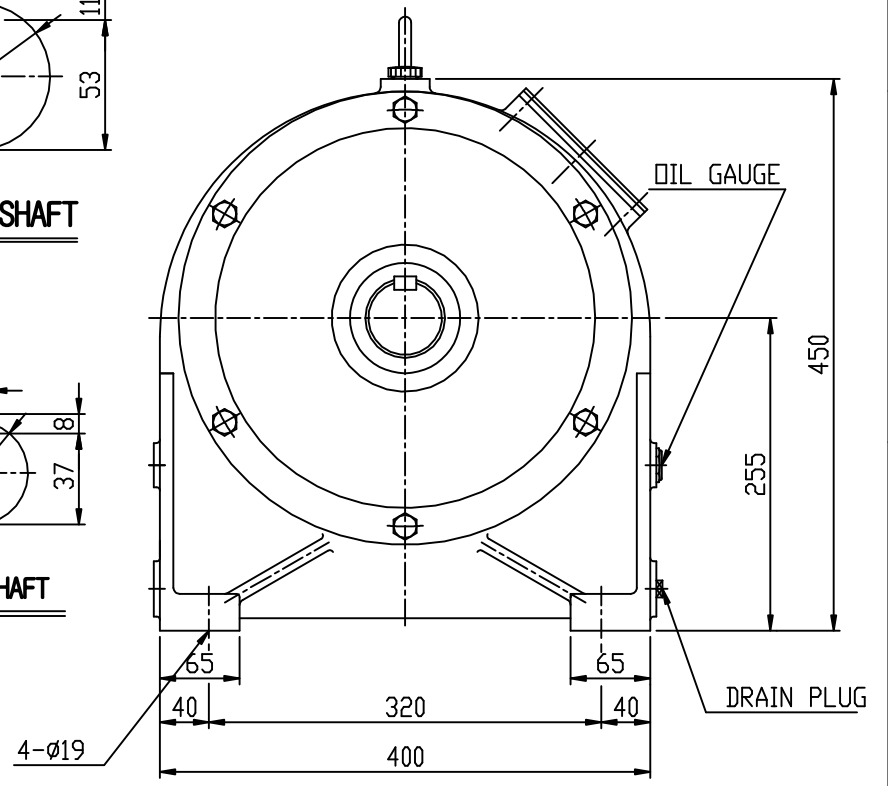

NO	PART NUMBER	DESCRIPTIONS	Q'TY	MATERIAL

표기의 표준 가공 및 공차	
각도: $\pm 0.5^\circ$	6 - 30 : ± 0.1
CHAMFER: C1.0	30 - 120 : ± 0.15
FILLET: R1.0	120 - 315 : ± 0.2
마무리: ∇	315 - 1000 : ± 0.3
열처리: HRC	1000 이상 : ± 0.5

DESIGNED	NAME	DATE
김영남	김영남	00.10.28
CHECKED		
APPROVED		

SAMYANG
 REDUCTION GEARS CO., LTD

DWG SIZE: $\Delta 4$
 DWG. NO.: SL2255-11K
 REV: /

A
B
C
D

A
B
C
D